

Smart Variable Laser Treatment Module

CHR40-15



Features

- Contact detection
- Skin-tone detection
- Changeable spot size
- Integration design
- High reliability

Applications

- Hair Removal

Product Dimensions (mm)

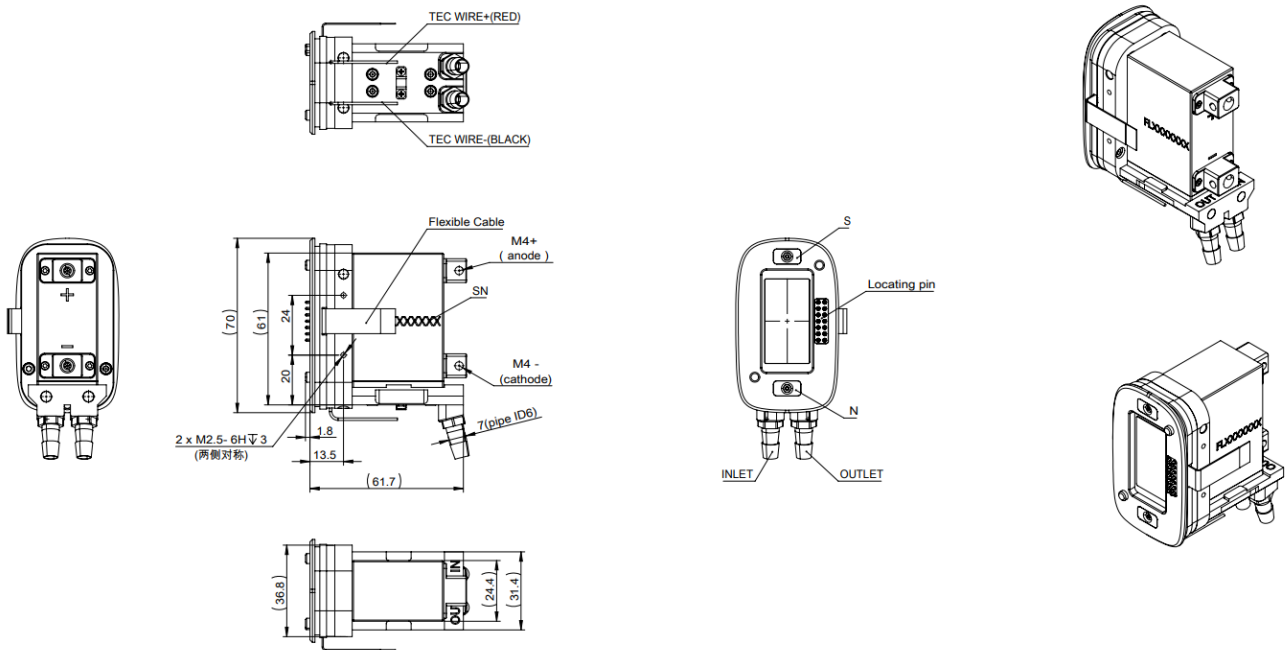

Product Dimensions (mm)

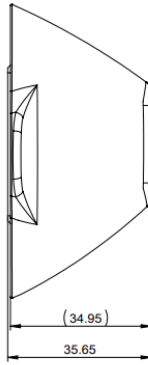
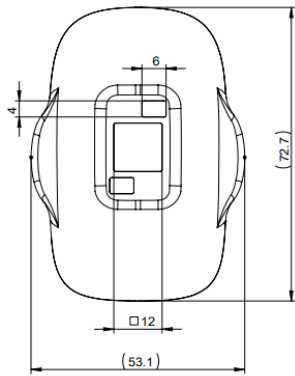

10X10

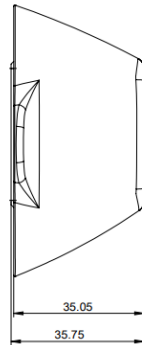
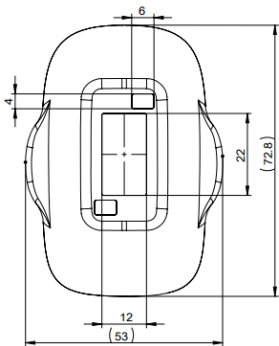
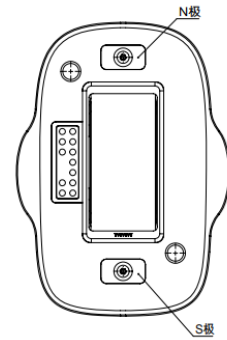

10X20

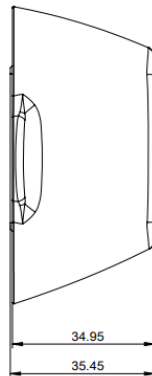
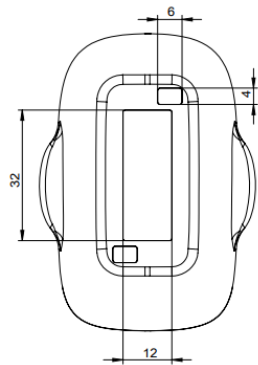
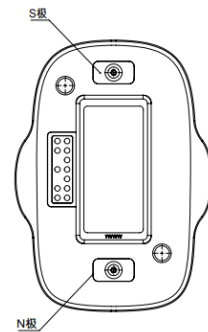

10X30

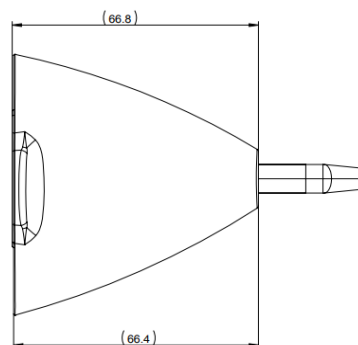
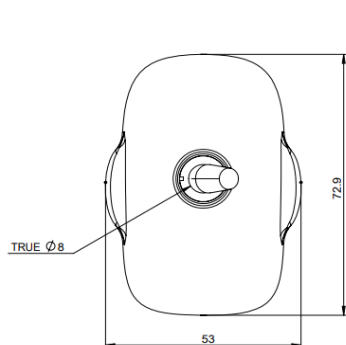
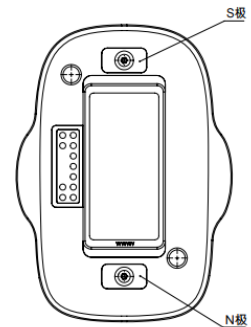

Φ6

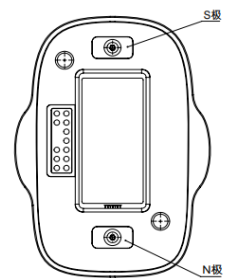

Product Specifications

Product Code

Part No. ¹

(Typical Configuration)

FL-CHR40-15-S-3000-808-QCW

Optical Parameters ²	Unit	Value
Centroid Wavelength	nm	808
Wavelength Tolerance	nm	± 15
Number of Bars	#	15
Spot Size	mm	10*10 / 10*20 / 10*30 / Ø6
Output Power of LD	W	3000
Output Power of Module	W	2550 (10*10mm); 2700 (10*20mm, 10*30mm); 1800 (Ø6mm)
Pulse width	ms	20
Frequency	Hz	10
Duty Cycle	%	20

Cooling Parameters

TEC I _{max}	A	~7
TEC V _{max}	V	~12

Electrical Parameters ³

Max. Operation Current I _{op}	A	≤ 178
Threshold Current I _{th}	A	≤ 25
Operating Voltage V _{op}	V	≤ 32
Operation Condition ⁴	-	Following Energy Table

Thermal parameters

Operating Temperature	°C	22 ~ 28
Coolant ⁵	-	Purified water with ion exchange resin filter (Replace every 3 months)
Flow Rate	L/min	4.25-5
Water Pressure	MPa	~0.5
Water Conductivity	uS/cm	≤5
Storage Temperature ⁶	°C	0~55

¹Part No. = Brand Code - Series - Bar No. - Additional Function - Platform Power Limit - Centroid Wavelength - Operation Mode

²Data at 25°C unless otherwise stated.

³Reduced lifetime if used above nominal operating conditions.

⁴The module should be operated following the energy table. Please contact your sales representative for energy tables.

⁵The cooling system should use materials which can bear cooling water corrosion, like stainless still or plastic.

⁶A non-condensing environment is required for storage and operation below ambient dew level.

